

Powering Brighter Tomorrow

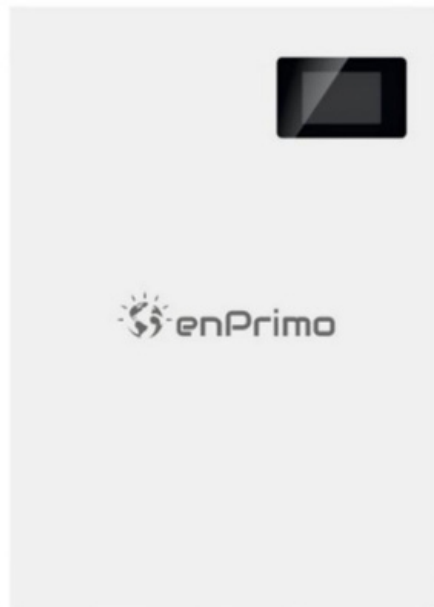

**ENP-10051-WME-LV**

**Energy Storage LiFePO<sub>4</sub> Battery**

**User Manual**

**MADE IN INDIA**

# Connection Diagram

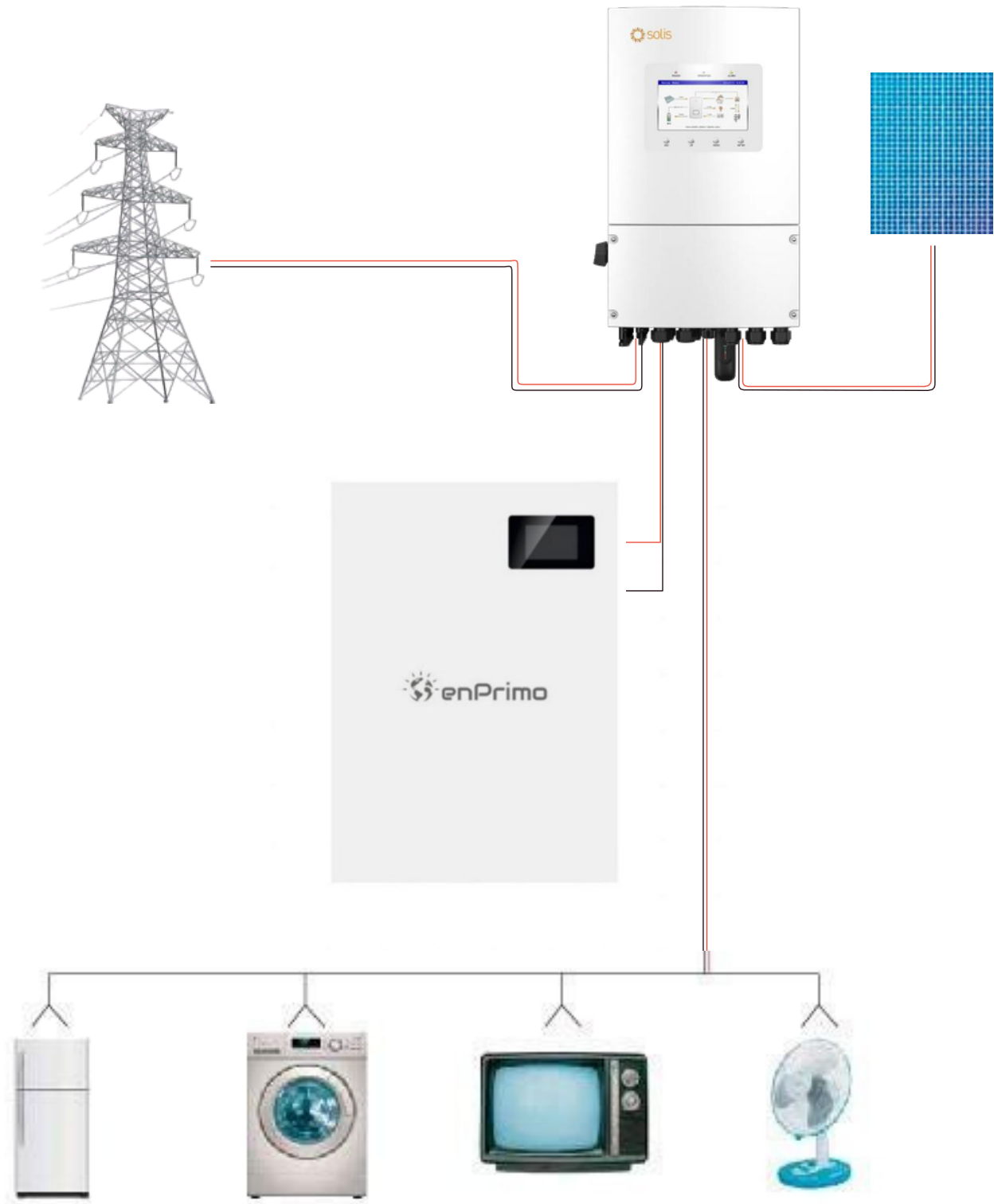

## Important safety instructions

**Important safety instructions Please keep this manual for future reference. This manual contains all the safety, installation and operation instructions of The wall mount-type energy storage LiFePO<sub>4</sub> battery. Please read all instructions and precautions in the manual carefully before installation and use.**

1. To avoid personal injury, users should have it disassembled by a professional installer.  
If you need repairs, please contact our company's professional maintenance personnel.
2. Do not install the energy storage LiFePO<sub>4</sub> battery in a place where children can touch.
3. Do not install the energy storage LiFePO<sub>4</sub> battery in harsh environments such as damp, greasy, flammable, explosive, or dusty environments.
4. When the energy storage LiFePO<sub>4</sub> battery is working, please do not open the box.
5. It is recommended to install a suitable fuse or circuit breaker externally.
6. After installation, check whether all line connections are tight to avoid the risk of heat accumulation due to a virtual connection.
7. Stack energy storage battery shall be charged with solar power or AC power supply, parallel connection with other AC power supply or different voltage and brand batteries is prohibited.

# Contents

|   |       |
|---|-------|
| <b>1.Basic information</b>                                  | 3~4   |
| <b>2.Installation process</b>                               | 5     |
| <b>3.Installation instructions</b>                          | 5~10  |
| 3.1 Installation notes                                      | 5~6   |
| 3.2 Installation and wiring                                 | 6     |
| 3.3 Schematic diagram of the installation                   | 7~9   |
| 3.4 Necessary Installation Tools                            | 10    |
| 3.5 Personal Protective Equipment +1000 Vdc Insulated Tools | 10    |
| <b>4.Schematic diagram of connecting</b>                    | 11~12 |
| <b>5.LED instructions</b>                                   | 13~14 |
| <b>6.BMS communication settings</b>                         | 15~18 |
| 6.1 BMS communication and setting                           | 15    |
| 6.2 Communication address selection specification           | 16    |
| 6.3 Inverter Compatibility List                             | 17    |
| 6.4 Low Voltage Battery to inverter CAN Terminal Pin Out    | 17~18 |
| 6.5 Low Voltage Battery to inverter RS485 Terminal Pin Out  | 18~19 |
| <b>7.Color touch screen instructions</b>                    | 19~21 |
| <b>8.Technical parameter list</b>                           | 22 23 |
| <b>9.Maintenance and conservation</b>                       | 24    |
| <b>10.Warranty record card</b>                              |       |

## 1. Basic information

### 1.1 Product overview

Wall mount-type energy storage batteries are mainly used for household power storage. At the same time, it is also suitable for LV internal energy storage, household energy storage, and temporary buildings. It adopts a high-performance, long-life lithium iron phosphate battery as the basic energy storage unit, combined with an advanced lithium-ion battery management system, industrial design for household products, and other technologies. Ensure that products are highly reliable and meet high industrialisation standards. Wall mount-type products can support external parallel use functions, greatly improving convenience through scientifically and rationally designed active heat dissipation. Wall mount-type energy storage battery improves the consistency of the internal temperature field, prolongs service life, and enables continuous high-current output.

### 1.2 Features

- ◆ The external color touch screen is used to monitor the energy storage battery data and operating status in real time.
- ◆ The battery adopts a high-performance lithium iron phosphate battery with high safety performance and long service life.
- ◆ An external weak current switch reduces product power consumption and improves the safety of transportation and storage.
- ◆ With the RS232/RS485/CAN communication function, it can easily communicate with the equipment.
- ◆ An external wireless module can be connected for remote data monitoring and corresponding control.
- ◆ The energy battery is equipped with a wall bracket to meet the installation and use of different places.
- ◆ It has multiple protection functions to safeguard the power supply in all-round ways.
- ◆ The output is stable and can be connected to different loads within the voltage range.
- ◆ Support up to 15 independent modules for parallel use.

### 1.3 Function description

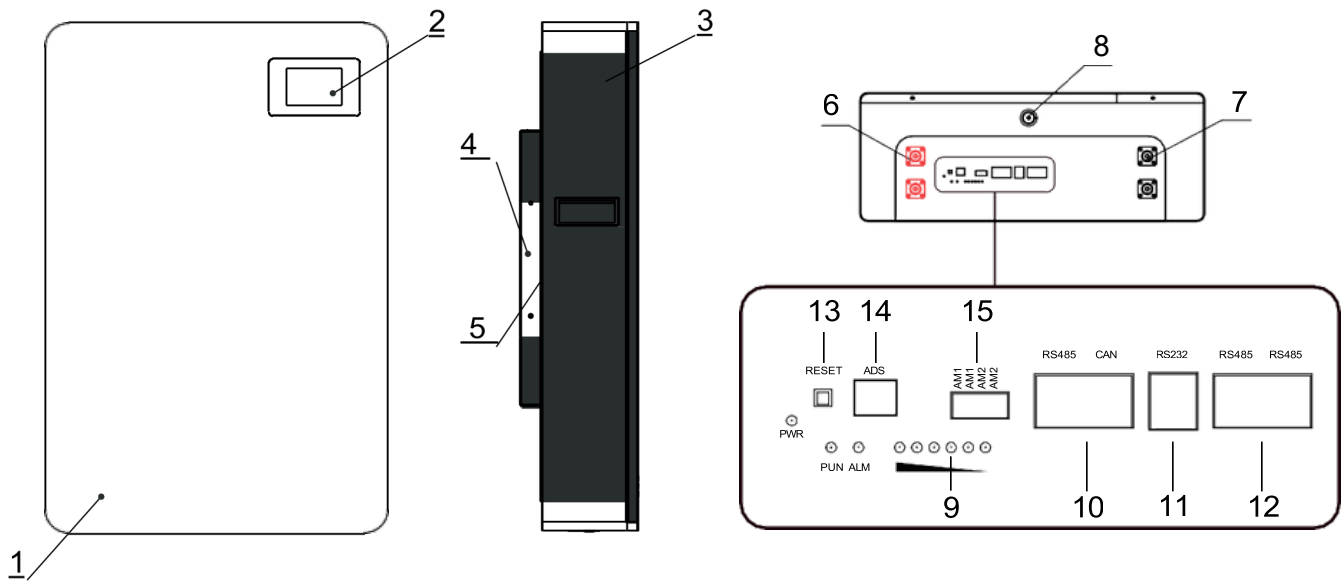

|   |                                |   |                                |
|---|--------------------------------|---|--------------------------------|
| 1 | White face cover               | 2 | Touch screen Wall mounted      |
| 3 | White cabinet                  | 4 | bracket                        |
| 5 | Handle                         | 6 | M6/M8 Positive terminal (2pcs) |
| 7 | M6/M8 Negative terminal (2pcs) | 8 | OFF/ON                         |

- 9 SOC Display: 6 LED indicators, with each one indicating about 17% SOC (State of Charge).
- 10 "RS485/CAN" battery can communicate with the INVERTER through RS485/CAN interface so that the inverter can monitor all kinds of battery information, including battery voltage, current, temperature, status, SOC, SOH, etc. The default baud rate is 9600bps.
- 11 RS232: it can monitor the single pack information by computer.
- 12 RS485/RS485: This interface is used in parallel with battery strings. The master-controlled Pack communicates with the slave-controlled Pack through the RS485 port, so that the information of all packs can be viewed through the RS485/CAN port by the master-controlled Pack. BTW, this RS-485 port cannot be used for parameter setting and corresponding controlled operation.
- 13 Reset: When the PACK is in the sleep state, press this key (3-6s) and release it to activate. If the PACK is in the active state, press this key (3-6s) and release it to sleep.
- 14 When "ADS" is used for parallel use of battery packs, different packs can be distinguished by hardware address, and the hardware address of each PACK in the whole battery stack is unique. The hardware address can be set in sequence by a DIP switch; the definition of the switch refers to "Instructions for Selecting Communication Address"
- 15 Dry contact AM1 is normally OPEN and CLOSED during fault protection; Dry contact AM2 is normally OPEN and CLOSED during low energy alarm.

## 2. Installation process

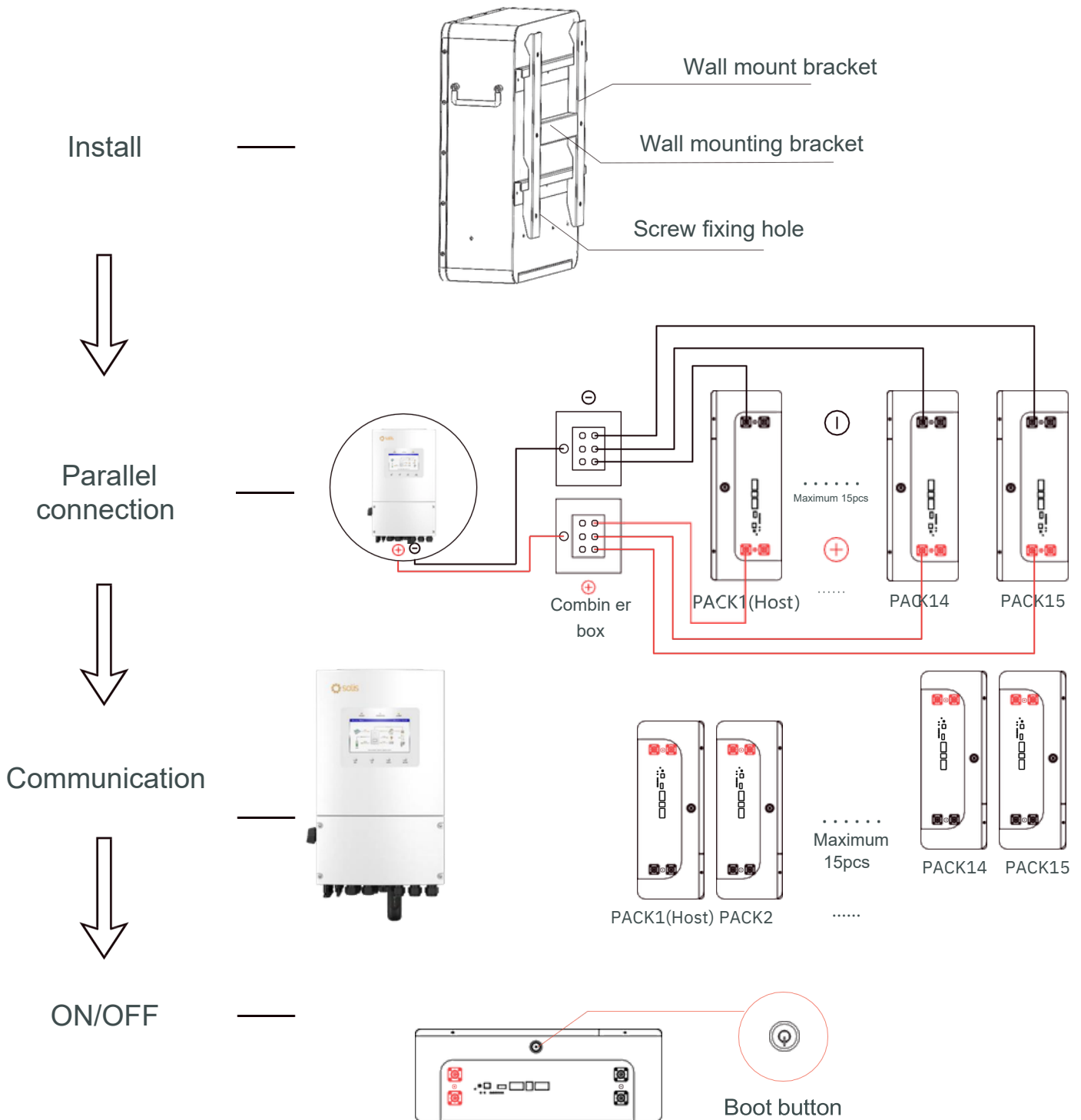

## 3. Installation instructions

### 3.1 Installation notes

Before installation, please read this manual carefully and familiarize the installation steps.

(1) Be sure to leave a certain space around for heat dissipation during installation.

- (2) Avoid direct sunlight and rainwater infiltration during outdoor installation to prevent battery damage.
- (3) Do not place metal products near the place of the energy storage LiFePO<sub>4</sub> battery installation to prevent short circuits.
- (4) Virtual connection points and corroded wires may generate high heat, and the molten insulation layer will burn surrounding materials and even cause a fire. Therefore, it must be ensured that the connector has been tightened, and the wires should be secured with cable ties to avoid loosening of the connector due to shaking during mobile applications.
- (5) After the battery switch is turned off, there is still high voltage inside the energy storage case. Please do not open or touch the internal components, and an external short circuit is strictly prohibited.
- (6) Please do not install it in a harsh environment where a large amount of damp, greasy, flammable and explosive dust gathers.
- (7) It is forbidden to reverse the charging and discharging terminals of the battery; it is very easy to damage the battery or cause unpredictable risks.
- (8) When installing the battery on the wall, you must first ensure the bearing capacity of the wall. Check the wall and check whether the screws are installed firmly to avoid unnecessary danger.
- (9) If an injury occurs during installation or use, please seek medical attention in time.

### **3.2 Installation and connection**

Installation and connection must comply with national and local electrical code requirements. According to the current situation, firstly, choose the corresponding wire or a wire with a larger wire diameter to avoid unnecessary troubles during use. Secondly, determine the installation location. Thirdly, when installing, please make sure to leave at least 200 mm of space at the air outlets on both sides of the energy storage battery to ensure natural convection heat dissipation.

### 3.3 Schematic diagram of the wall-mounted installation

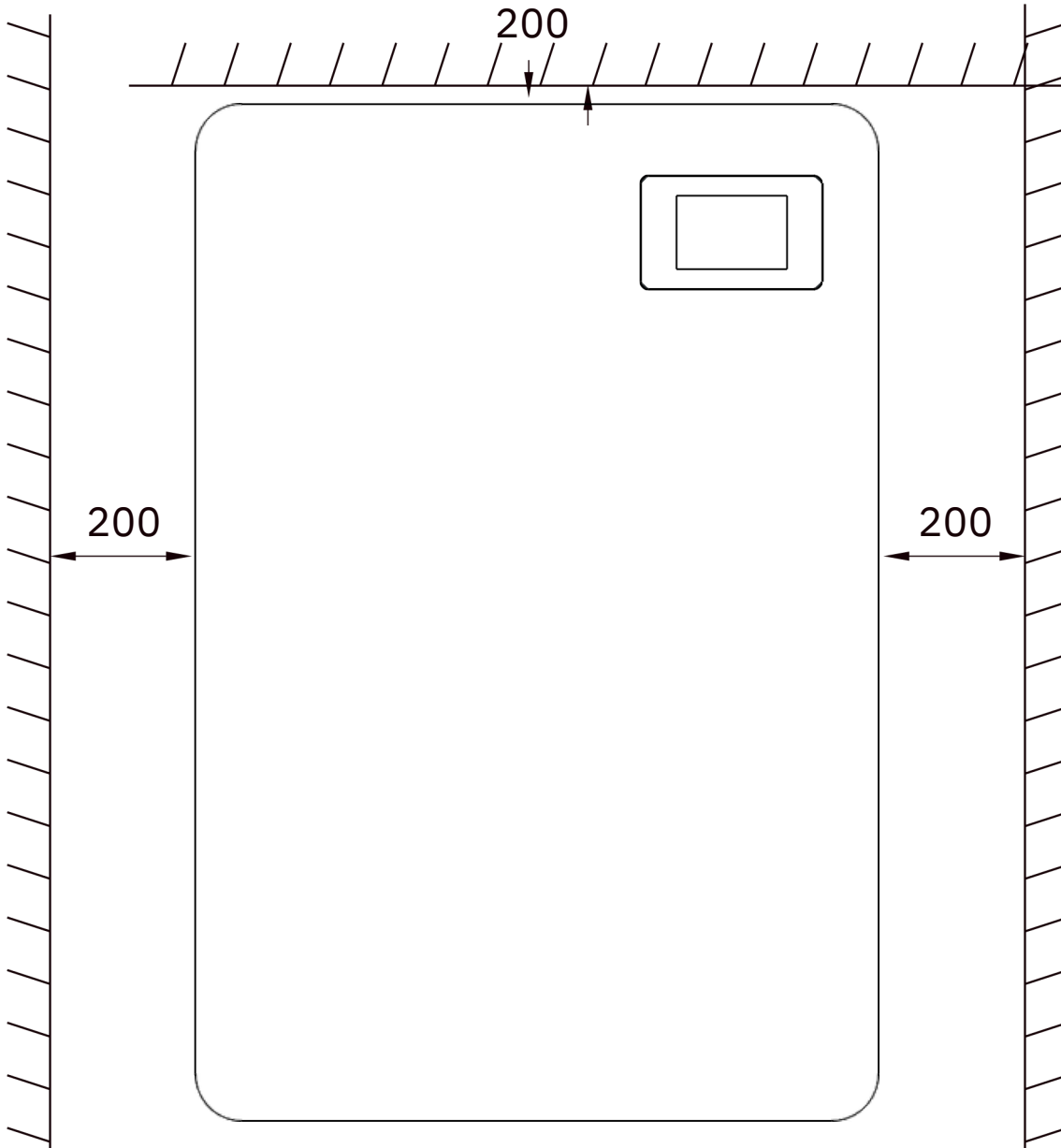



**Warning:** Danger of explosion! In order to avoid accidents, do not reverse-connect the charging and discharging ports or create a short circuit, and do not install them in a closed environment. Rainproof and moisture-proof protection must be installed outdoors.

**Attention!!** The above steps can be omitted without wall mounting.

**Attention!!** Before making the final DC connection, please ensure that the battery switch / DC circuit breaker is disconnected, and ensure that the positive (+) is connected to the positive (+), and the negative (-) is connected to the negative (-).

Recommended external wiring diameter and switch selection.

| Model            | Recommended external wiring diameter | The system is continuously current | Circuit breaker |
|------------------|--------------------------------------|------------------------------------|-----------------|
| ENP-10051-WME-LV | 25mm <sup>2</sup>                    | 100A                               | 2P-125A         |

Note: The wiring diameter is for reference only. If the distance between the load and the battery is relatively long, a larger wire can be used to reduce the line resistance and improve system performance. The above wire diameter and circuit breaker are only suggestions; please follow the actual situation to choose the appropriate wire diameter and circuit breaker.

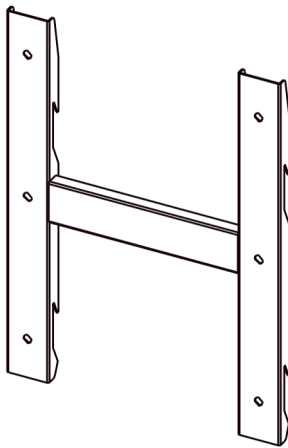

Picture 1

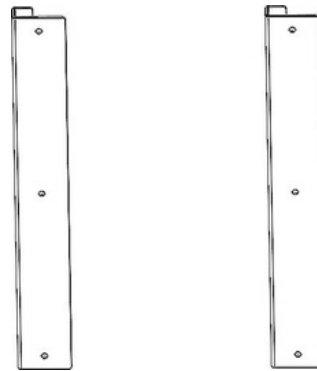

Picture 2

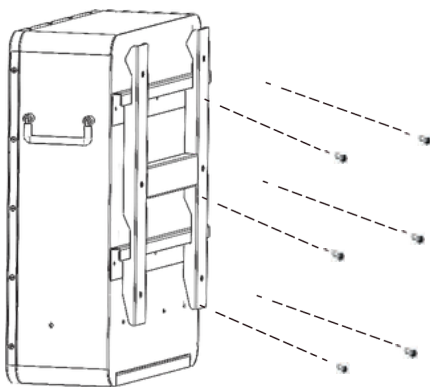

Picture 3

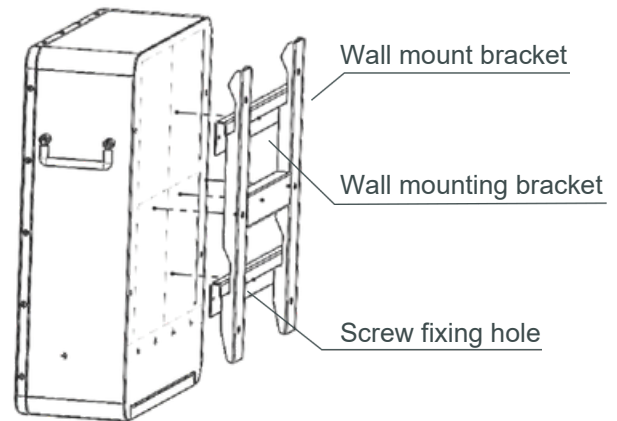

Picture 4









As shown in the pictures above:

(1) According to the actual situation, first install the wall mounting plate with an M8 expansion screw on the wall to ensure that the installation is firm (picture 1).

Note: the height of the expansion screw protruding from the wall shall be controlled within 25mm to avoid interference with the battery box during installation (Picture 2).

(2) Fix the wall mounting bracket on the outer box of the battery with M6 screws, and ensure that the bolts are tightened with a torque of 2-3 nm (Picture 3).

### 3.4 Necessary Installation Tools

|   |  |   |  |
|---|--|---|--|
|  <p>Multimeter + Current clamp</p> |  <p>Insulated Screwdriver Set</p>       |  <p>Insulated Allen Key Set<br/>from 2 mm to 8 mm</p> |  <p>Drill+Hammer</p>                              |
|  <p>Electrician Scissors</p>       |  <p>Insulated Torque<br/>Wrench Set</p> |  <p>Lifting Strap +<br/>Mechanical Lifter</p>         |  <p>RS232/USB +Screw<br/>Terminal (insulated)</p> |

### 3.5 Personal Protective Equipment +1000 Vdc Insulated Tools



#### 4. Schematic diagram of connecting

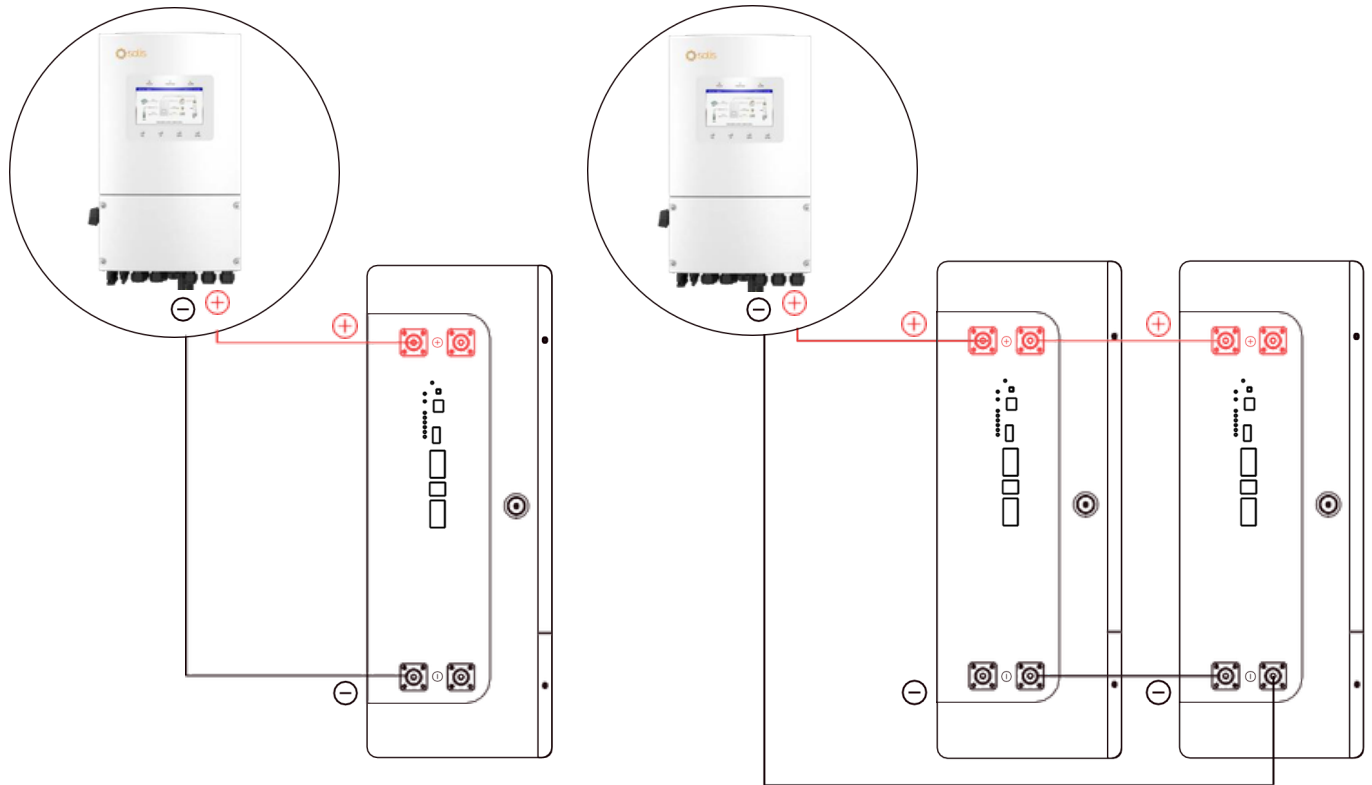

① One unit product

② Two units products

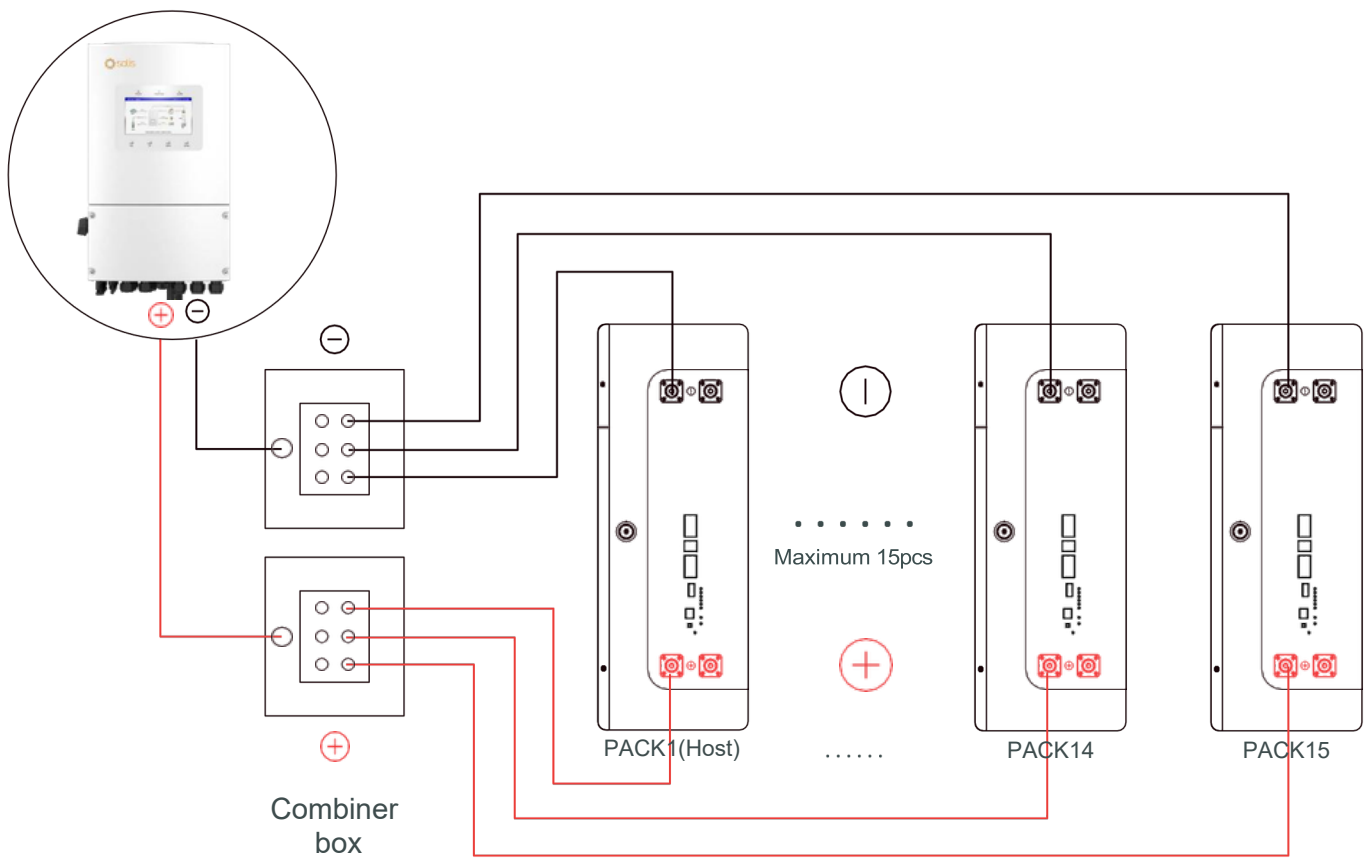

③ More than Two units' products

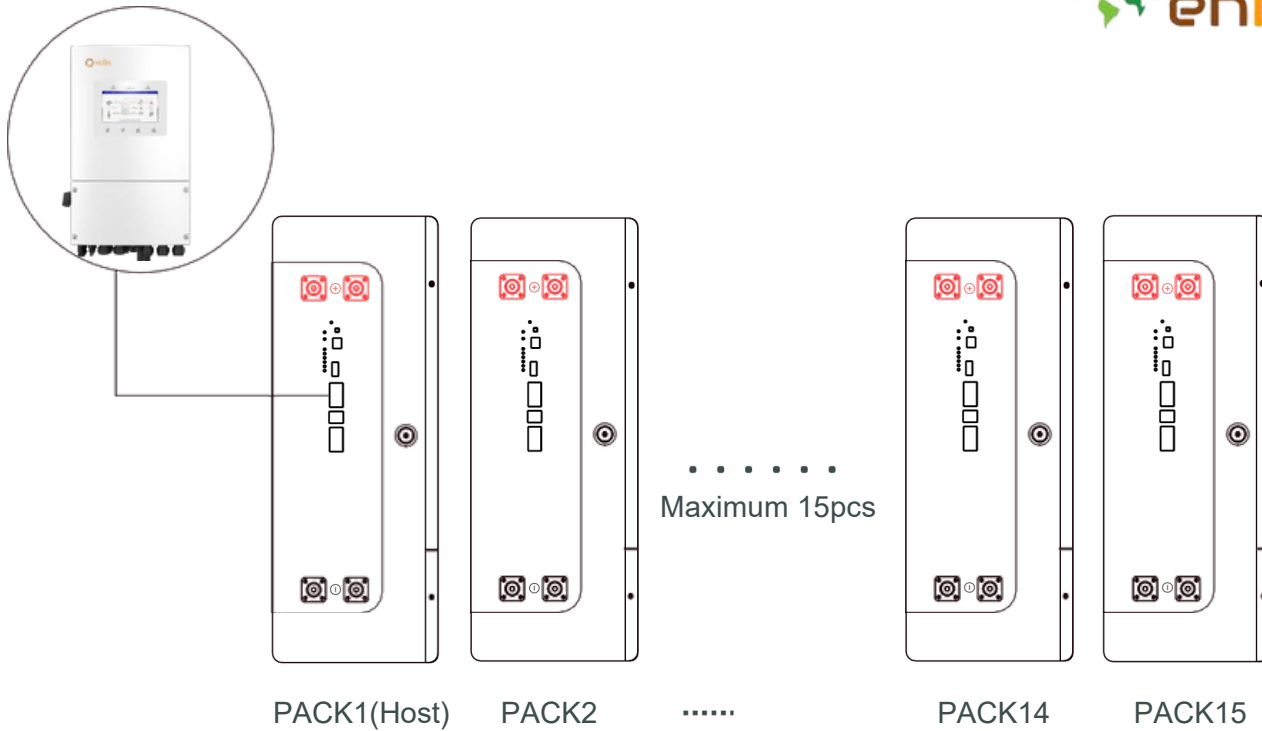

④ Batteries are connected in communication

Note: 1. When the battery pack is used in parallel, it is necessary to distinguish different packs by hardware address, and the hardware address of each pack in the whole battery pack is unique.

2. It must set up a pack for the host pack. The inverter communicate with the host pack via RS485/CAN. The hardware address can be set successively through the dial switch on the board.

3. After the battery connected to the inverter, turn on the inverter for 5 minutes before turning on the battery, to prevent the BMS being burned out by the excessive surge voltage of the inverter.

Recommended setting data for the inverter:

|                           |                         |
|---------------------------|-------------------------|
| Battery model             | LiFePO4/Lithium battery |
| Model                     | ENP-10051-WME-LV        |
| Discharge cut-off voltage | 50                      |
| Over-discharge recovery   | 51                      |
| Normal charging voltage   | 51.2                    |
| Overvoltage protection    | 58.4                    |
| Overvoltage recovery      | 56                      |
| Discharge cut-off SOC     | 10%                     |

## 5.LED instructions

Table1 LED working status indication

| State     | normal/warning/protect  | RUN           | ALM           | Battery indicator LED   |               |               |               | illustrate  |
|-----------|---|---------------|---------------|---|---------------|---------------|---------------|---|
|           |   | ●             | ●             | ●   | ●             | ●             | ●             |   |
| Shutdown  | hibernate   | extinguish    | extinguish    | extinguish  | extinguish    | extinguish    | extinguish    | annihilate  |
| Standby   | normal  | flash 1       | extinguish    | According to the battery indicator  |               |               |               | standby mode  |
|           | alert   | flash 1       | flash 3       |   |               |               |               | Module low voltage  |
| Charge    | normal  | Always bright | extinguish    | According to the battery indicator (battery indication maximum LED flashes 2) |               |               |               | Maximum battery LED flashes Move (flashing 2), overcharge warning ALM does not flash during alarm |
|           | alert   | Always bright | flash 3       |   |               |               |               |   |
|           | Overcharge protection   | Always bright | extinguish    | Always bright   | Always bright | Always bright | Always bright | If there is no utility power, indicate Light goes to standby                                      |
|           | temperature, overcurrent, Failsafe                                    | extinguish    | Always bright | extinguish  | extinguish    | extinguish    | extinguish    | stop charging   |
| Discharge | normal  | flash 3       | extinguish    | According to the battery indicator  |               |               |               | stop charging   |
|           | alert   | flash 3       | flash 3       |   |               |               |               |   |
|           | Undervoltage protection   | extinguish    | extinguish    | extinguish  | extinguish    | extinguish    | extinguish    | stop charging   |
|           | temperature, overcurrent, short circuit, Reverse connection, failsafe | extinguish    | Always bright | extinguish  | extinguish    | extinguish    | extinguish    | stop charging   |
| Invalid   |   | extinguish    | Always bright | extinguish  | extinguish    | extinguish    | extinguish    | Stop charging and discharging   |

Table2 Description of capacity indication

| state              | Charge   |            |            |            |            |            |                 | discharge  |            |            |            |            |          |  |
|--------------------|----------|------------|------------|------------|------------|------------|-----------------|------------|------------|------------|------------|------------|----------|--|
| capacity indicator | L6 ●     | L5 ●       | L4 ●       | L3 ●       | L2 ●       | L1 ●       | L6 ●            | L5 ●       | L4 ●       | L3 ●       | L2 ●       | L1 ●       |          |  |
| Battery (%)        | 0~17%    | extinguish | extinguish | extinguish | extinguish | extinguish | flash 2         | extinguish | extinguish | extinguish | extinguish | extinguish | constant |  |
|                    | 18~33%   | extinguish | extinguish | extinguish | extinguish | flash 2    | constant        | extinguish | extinguish | extinguish | extinguish | constant   | constant |  |
|                    | 34~50%   | extinguish | extinguish | extinguish | flash 2    | constant   | constant        | extinguish | extinguish | extinguish | constant   | constant   | constant |  |
|                    | 51~66%   | extinguish | extinguish | flash 2    | constant   | constant   | constant        | extinguish | extinguish | constant   | constant   | constant   | constant |  |
|                    | 67~83%   | extinguish | flash 2    | constant   | constant   | constant   | constant        | extinguish | constant   | constant   | constant   | constant   | constant |  |
|                    | 84~100%  | flash 2    | constant   | constant   | constant   | constant   | constant        | constant   | constant   | constant   | constant   | constant   | constant |  |
| Running lights ●   | constant |            |            |            |            |            | Blink (blink 3) |            |            |            |            |            |          |  |

Table 3 LED flashing description

| flashing method | Bright | extinguish |
|-----------------|--------|------------|
| flash 1         | 0.25S  | 3.75S      |
| flash 2         | 0.5S   | 0.5S       |
| flash 3         | 0.5S   | 1.5S       |

Remarks: The LED indicator alarm can be enabled or disabled through the host computer, and the factory default is enabled.

### ◆ Key Description

1. In the normal operation state, the system enters the sleep/shutdown state after 3 minutes of keyless operation.
2. In the shutdown/hibernate state, operate any button, and the display will be activated, and the main status interface will be entered.
3. After the BMS is reset, the parameters and functions set by the host computer are still retained. If it is necessary to restore the initial parameters, it can be achieved through the "restore default value" of the host computer, but the relevant operation records and stored data remain unchanged (such as power, cycle times, etc.).

## 6.BMS communication settings

### 6.1 BMS communication and setting

When the load (such as an inverter) needs to communicate with the battery, to establish normal communication with the load, the BMS needs to set The following settings for each brand. The RS485/CAN communication protocols of inverters are different, but there are several RS485/CAN communication protocols inside the inverter to match the battery. When using, you can directly select the communication protocol code in the inverter for matching. If you have other problems, please consult the supplier.

Battery BMS interface pin foot definition as shown in the following figure

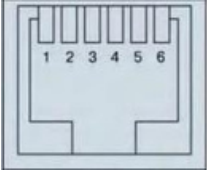
|  |  |    |    |    |     |
|--|--|----|----|----|-----|
|  <p>RS232<br/>Communication interface</p> | The battery communication interface adopts 8P8C RJ45 socket. |    |    |    |     |
|  | PIN  | 2  | 3  | 4  | 5   |
|  | Definition   | NC | TX | RX | GND |

|  |  |         |         |       |       |
|--|--|---------|---------|-------|-------|
|  <p>RS485<br/>Communication interface</p> | The battery communication interface adopts 8P8C RJ45 socket. |         |         |       |       |
|  | PIN  | 1、 8    | 2、 7    | 4     | 5     |
|  | Definition   | RS485-B | RS485-A | CAN-H | CAN-L |



ADS

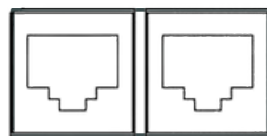

RS485

CAN

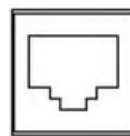

RS232

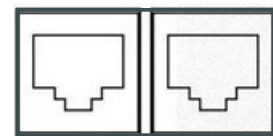

RS485

RS485

- ◆ “ADS” is used for parallel use of battery packs. PACK can be distinguished by hardware address. The definition of ADS master-slave address refers to communication address selection specification.
- ◆ “RS232” it can monitor the single pack information by computer.
- ◆ “RS485/RS485” is used in parallel for battery pack, and the main communicates with pack from the interface.
- ◆ “RS485/CAN” battery pack can communicate with the inverter through this interface.

**Note:** The battery default protocol is Pylon.

## 6.2 Communication address selection specification



| Address | Code switch position |     |     |     | Illustrate                  |
|---------|----------------------|-----|-----|-----|-----------------------------|
|         | 1#                   | 2#  | 3#  | 4#  |                             |
| 0       | OFF                  | OFF | OFF | OFF | Stand-alone use, no cascade |
| 1       | ON                   | OFF | OFF | OFF | Set to Pack 1 (Host)        |
| 2       | OFF                  | ON  | OFF | OFF | Set to Pack 2               |
| 3       | ON                   | ON  | OFF | OFF | Set to Pack 3               |
| 4       | OFF                  | OFF | ON  | OFF | Set to Pack 4               |
| 5       | ON                   | OFF | ON  | OFF | Set to Pack 5               |
| 6       | OFF                  | ON  | ON  | OFF | Set to Pack 6               |
| 7       | ON                   | ON  | ON  | OFF | Set to Pack 7               |
| 8       | OFF                  | OFF | OFF | ON  | Set to Pack 8               |
| 9       | ON                   | OFF | OFF | ON  | Set to Pack 9               |
| 10      | OFF                  | ON  | OFF | ON  | Set to Pack 10              |
| 11      | ON                   | ON  | OFF | ON  | Set to Pack 11              |
| 12      | OFF                  | OFF | ON  | ON  | Set to Pack 12              |
| 13      | ON                   | OFF | ON  | ON  | Set to Pack 13              |
| 14      | OFF                  | ON  | ON  | ON  | Set to Pack 14              |
| 15      | ON                   | ON  | ON  | ON  | Set to Pack 15              |

### 6.3 Inverter Compatibility List

| Inverter Brand  | Model  | Battery Protocol Selection | Battery Modules |
|-----------------|--------|----------------------------|-----------------|
| Growatt         | LV ALL | Pylon                      | 15              |
| SRNE            | LV ALL | Pylon                      | 15              |
| Voltronic power | LV ALL | Pylon                      | 15              |
| Goodwe          | LV ALL | Pylon                      | 15              |
| Deye            | LV ALL | Pylon                      | 15              |
| Luxpower        | LV ALL | Pylon                      | 15              |
| Megarevo        | LV ALL | Pylon                      | 15              |
| SAKO            | LV ALL | Pylon                      | 15              |
| Sorotec         | LV ALL | Pylon                      | 15              |
| SMK Solar       | LV ALL | Pylon                      | 15              |
| Inhenergy       | LV ALL | Pylon                      | 15              |
| MUST            | LV ALL | Pylon                      | 15              |
| SUNGROW         | LV ALL | Pylon                      | 15              |
| Afore           | LV ALL | Pylon                      | 15              |
| Solis           | LV ALL | Pylon                      | 15              |
| Felicity        | LV ALL | Pylon                      | 15              |
| Frecon          | LV ALL | Pylon                      | 15              |

### 6.4 Low Voltage Battery to inverter CAN Terminal Pin Out

| LOW VOLTAGE INVERTER CAN /BMS   |              |                        |                            |                                |
|---|--------------|------------------------|----------------------------|--------------------------------|
| <br>RJ45 | CAN TERMINAL | Inverter Terminal Type | Inverter SIDE (PIN Number) | Battery SIDE RJ45 (PIN Number) |
| Goodwe  | CAN- H       | RJ45                   | 4                          | 4                              |
|   | CAN- L       |                        | 5                          | 5                              |
| Deye  | CAN- H       | RJ45                   | 4                          | 4                              |
|   | CAN- L       |                        | 5                          | 5                              |

|           |        |      |   |   |
|-----------|--------|------|---|---|
| Luxpower  | CAN- H | RJ45 | 4 | 4 |
|           | CAN- L |      | 3 | 5 |
| Megarevo  | CAN- H | RJ45 | 4 | 4 |
|           | CAN- L |      | 5 | 5 |
| Sorotec   | CAN- H | RJ45 | 3 | 4 |
|           | CAN- L |      | 5 | 5 |
| Inhenergy | CAN- H | RJ45 | 4 | 4 |
|           | CAN- L |      | 5 | 5 |
| MUST      | CAN- H | RJ45 | 6 | 4 |
|           | CAN- L |      | 5 | 5 |
| SUNGROW   | CAN- H | RJ45 | 4 | 4 |
|           | CAN- L |      | 5 | 5 |
| Afore     | CAN- H | RJ45 | 4 | 4 |
|           | CAN- L |      | 5 | 5 |
| Felicity  | CANL1  | RJ45 | 7 | 5 |
|           | CANH1  |      | 8 | 4 |

## 6.5 Low Voltage Batteryto Inverter RS-485 Terminal Pin Out

| LOW VOLTAGE INVERTER RS485  |                |                        |                            |                                |
|---|----------------|------------------------|----------------------------|--------------------------------|
| <br>RJ45 | RS485 TERMINAL | Inverter Terminal Type | Inverter SIDE (PIN Number) | Battery SIDE RJ45 (PIN Number) |
| Growatt   | RS485-B        | RJ45                   | 1                          | 1, 8                           |
|   | RS485-A        |                        | 2                          | 2, 7                           |
| SRNE  | RS485-B        | RJ45                   | 8                          | 1, 8                           |
|   | RS485-A        |                        | 7                          | 2, 7                           |
| Voltronic power   | RS485-B        | RJ45                   | 3                          | 1, 8                           |
|   | RS485-A        |                        | 5                          | 2, 7                           |
| SAKO  | RS485-B        | RJ45                   | 3                          | 1, 8                           |
|   | RS485-A        |                        | 5                          | 2, 7                           |
| Frecon  | RS485-B        | RJ45                   | 1                          | 1, 8                           |
|   | RS485-A        |                        | 2                          | 2, 7                           |

|           |         |      |   |      |
|-----------|---------|------|---|------|
| SMK Solar | RS485-B | RJ45 | 1 | 1, 8 |
|           | RS485-A |      | 2 | 2, 7 |
| Solis     | RS485-B | RJ45 | 1 | 1, 8 |
|           | RS485-A |      | 2 | 2, 7 |

### INFORMATION

Regarding the communication between the battery and the inverter, the battery side needs to maintain the original configuration, but inverters of different brands and models may have different communication pins. If in doubt, refer to the inverter manual.

## 7. Color touch screen instructions

### 1. Home page

After power-on activation, the power-on interface will be displayed, as shown in the following figure:



### 2. Parallel batteries info page

After touching left round button from home screen, you will enter into the parallel info



### 3. Protocol selection page

After touching second left round button from the home screen, you will enter in protocol selection page:



### 4. Display sleep & language setting

After touching third left round setting button from the home screen, you will enter into sleep & language setting page

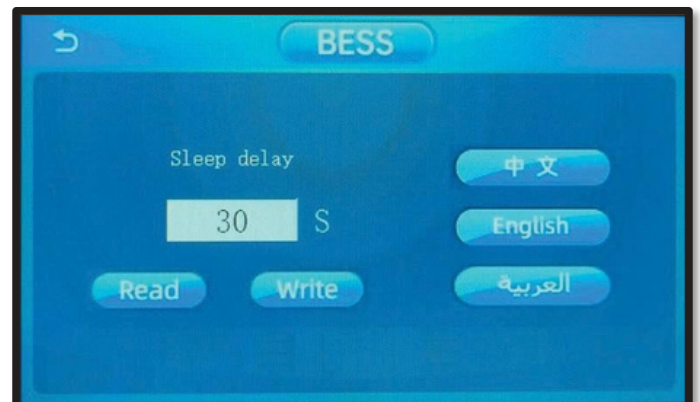

5. System Info Page After touching right round button from home screen, you will enter system info page:

Protection page  
After touching yellow colour alert symbol, you will enter the protection page:

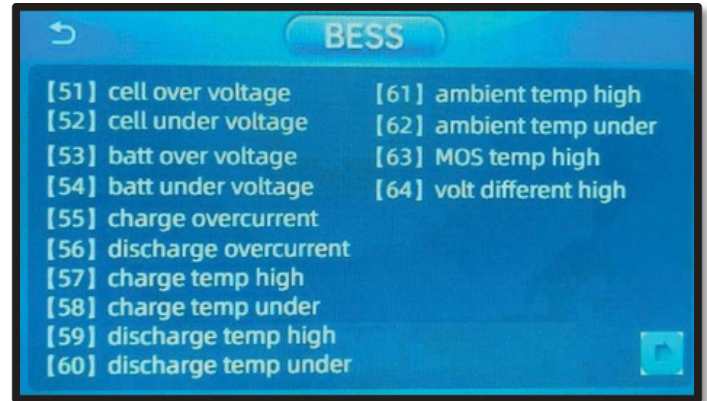

## 6. Key description

- (1) Each page can be accessed from home screen touch button present in bottom navigation bar.
- (2) In the dormant state, touch anywhere on the screen to activate the display.
- (3) Protection screen will only appear when protection is present in the battery pack.

## 7. Sleep/Shutdown

In normal operation, the system will enter the hibernation/shutdown state after 3 minutes of keyless operation.

In the shutdown/hibernate state, operate any button, the display will be activated and the main status interface will be entered.

## 8.All date of LCD display

### ◆ CTP28/35-1.1

#### › MIN STATE PAGE

WAIT for 5s,  
show min state page

Total SOC

Current

Voltage

Warranty

#### › HOME

##### PACK Info

- Pack V
- Temperature
- Cell voltage
- Cell capacity

##### BMS Status

- Packs status
- Protect
- Warning
- Fault

##### SYSTEM

- PACK SN
- Language selection:
  - English
  - Chinese

#### PROTOCOL

##### • CAN

- SO FAR PROTOCOL
- Shouhang energy storage inverter BMS general CAN protocol V 2.1.00220191204
- GOOD WE PROTOCOL
- LV BMS Protocol(CAN) for Solar Inverter Family EN\_V 1.5
- PYLON PROTOCOL 2.0
- Pylon CAN bus protocol V 2.0.420211122
- SMA PROTOCOL
- SMAF SS-Connecting Bat-TI-en-20W
- GROW ATT\_PROTOCOL
- Grow at tBM SCAN-Bus-protocol-low-voltage-V 1.04

##### • RS485

- USER\_485\_VOLTRON
- Vol tronic Inverter and BMS 485 communication protocol 20200325(1)
- USER 485PYLON
- RS485-protocol-pylon-low-voltage - Added protocol design V 3.5
- USER\_485\_LUX POWER
- Lux power tek Battery Protocol RS 485\_V 01

## 8. Technical parameter list

|  |   |
|--|---|
| Model                                  | ENP-10051-WME-LV                          |
| Array Mode                             | 16S                                       |
| Nominal Energy (kWh)                   | 5.12                                      |
| Nominal Voltage (V)                    | 51.2                                      |
| Charge Voltage (V)                     | 58.4                                      |
| Discharge Cut-off Voltage (V)          | 42  |
| Standard Charging Current(A)           | 20  |
| Max.Continuous Charging Current (A)    | 50  |
| Max.Continuous Discharging Current (A) | 100                                       |
| Communication Mode                     | RS232/RS485/CAN                           |
| Cycle Life                             | 6000 Cycles @80% DOD @25°C @0.2C/0.2C     |
| Operating Temp                         | Charging: 0~60°C; Discharging: -10°C~60°C |
| Size(LxWxH) mm                         | 560x470x170                               |
| Net Weight (Kg)                        | ≈46                                       |
| Gross Weight (Kg)                      | ≈52                                       |

Note: The dimensions are the product appearance dimensions. If any changes in the products, will be adjusted by the manufacturer.

## 9.Maintenance and conservation

| Item | Problem description   | Possible causes   | Solution   |
|------|---|---|--|
| 1    | The battery cannot be turned on normally, and there is no response when pressing the button.  | 1. The button is damaged or the button cable is disconnected;<br>2. BMS damaged;<br>3. The battery is seriously over-discharged.  | 1. Check whether the button is normal;<br>2. Check whether the voltage of the battery pack is normal;<br>3. If the voltage of the battery pack is too low, you need to use a constant current power supply or a lithium battery charger to charge the battery until the low voltage protection is released.  |
| 2    | The BMS immediately enters the protection state after pressing the switch.  | 1. Battery pack voltage is abnormal;<br>2. Abnormal temperature;<br>3. External load mismatch.  | 1. Check whether the voltage of the battery pack itself is consistent;<br>2. Check whether the BMS voltage collection is abnormal;<br>3. Confirm whether the ambient temperature exceeds the BMS temperature preset value and whether the temperature probe is damaged;<br>4. Determine whether the load power and voltage match the battery.  |
| 3    | Display screen does not display.  | 1. Display screen failure;<br>2. connection cable failure;<br>3. communication failure.   | 1. Press the power button to restart;<br>2. Check whether the display is damaged;<br>3. Check whether the cable is intact, whether there is any damage, disconnection, etc., and whether the connector is plugged in properly.   |
| 4    | The communication fault occurs when the load is inverter  | 1. Communication line connection error (improper pin connection or poor contact);<br>2. Does not match the inverter communication protocol;<br>3. Communication mode do not match;<br>4. Correspondence address error;<br>5. Signal interference. | 1. Check whether each pin of the communication line is broken;<br>2. Check whether the corresponding pins are connected correctly;<br>3. Check whether the contact part of the communication cable connection terminal is oxidized;<br>4. Confirm whether the inverter selects the matching protocol;<br>5. Confirm whether the correct communication method is selected, such as CAN and RS485 or other communication methods;<br>6. Confirm whether the inverter needs to select a communication address, and confirm whether the battery communication address is correct;<br>7. Confirm whether there are high-frequency interference sources in the battery usage scenario. |
| 5    | The output is suddenly disconnected during use  | 1. The battery voltage is too low, triggering BMS protection;<br>2. BMS protection caused by excessive load power or short circuit at the output end.   | 1. Check whether the battery voltage is within the normal range. If the voltage is low, charge the battery;<br>2. Adjust the load power to match; short circuit: disconnect the load or restart the battery.   |
| 6    | SOC does not match actual value   | 1. SOC cumulative error during charging and discharging;<br>2. SOC is not calibrated;<br>3. The internal battery parameters of BMS have changed.  | 1. Calibrate the SOC, discharge to battery protection and then charge to 100% of the battery to complete the calibration;<br>2. After the parameters related to the internal battery capacity of the BMS change, the SOC needs to be re-estimated and a power calibration needs to be performed.   |
| 7    | In order to protect your rights and interests, after you purchase our products, if you encounter problems with the installation and use of the product, you can contact the supplier, and we will provide you with after-sales service as soon as possible. |   |  |

To maintain the best and long-term performance, the following items are Recommended to be inspected twice a year.

1. Confirm that the surrounding air flow will not be blocked, and remove any dirt and debris from the cooling hole.
2. Check all exposed wires, shabby and damaged, please place or repair them if necessary.
3. If it is not be used for a long time, it is recommended to charge it every three months.



**Danger of electric shock! Make sure that the power supply has been disconnected during the above operations, and then carry out the corresponding inspection and operation.**

## Warranty Card and Warranty Condition

### Product Information

Battery Model

Serial No.

Purchase Date

Dealer/Installer

Commissioning Date

Seal of Dealer/Installer

### End User Information

Customer Name

Phone Number

Email

Detailed Address

## 1. Purpose

The primary purpose of this warranty letter is to clearly define the matters related to the warranty policy of the products.

## 2. Warranty Condition

### 2.1 Limitation of Warranty Scope

enPrimo liability under this Warranty Letter shall be limited to replacement, repair, refund and compensation. Replaced or repaired Products shall be warranted for the remainder of the original Term of Performance Warranty. In any event, the replacement shall not justify the renewal of the Term of Performance Warranty.

### 2.2 Exclusion of Warranty

Damage to the Products resulting from any of the following activities is NOT covered by this Limited Warranty:

Improper transportation, storage, installation or wiring by Buyer. Modification, alteration, disassembly, repair or replacement by someone other than personnel certified by enPrimo. Noncompliance with enPrimo's official installation manual. External influences, including unusual physical or electrical stress (power failure surges, inrush current, lightning, flood fire, accidental breakage, etc.) Use of an incompatible inverter, rectifier or PCS.

### 2.3 Warranty Claim

In general, serial number(S/N) must be provided in order to claim warranty. Please store the original purchasing invoice/ installation documents or receipts carefully. Customers need to present it for a warranty claim if required. Buyer shall contact the supplier directly for any warranty claims in order to avoid additional problems with the products.

Note:Products are unavailable to protect themselves from the self-discharge in the

condition of shutdown mode. So please charge the batteries to 80% every 3-6 months.

## 3. Performance Warranty (Standard)

enPrimo warrants and represents that the Product retains at least a cycle life of 6000 Times @80% DOD, 25°C, 0.2C charge and discharge with 80% DOD. Standard for 5-year warranty with 6000 cycle @80% DOD, 25°C, 0.2 °C. The ambient temperature during the operation of the Products shall not fall below 0°C or exceed 60°C

### Capacity measurement condition

Ambient temperature: 77 ~ 86°F (25 ~ 30°C) Initial battery temperature from BMS: 77 ~ 86°F (25 ~ 30°C) Charging/discharging method - 0.2C charge & discharge with 80% DOD Current and voltage measurement at battery DC side

#### **4. Out of Warranty Policy**

If damage to the products is not caused by the seller, the buyer shall provide charged service, including all expenses such as material cost, labour cost, warehouse cost, transportation cost, customs duties, analysis cost, management cost, corporate profits, disposal expense (if necessary) and so on.

#### **5. Warranty Guarantee**

For the goods that have passed the acceptance inspection, if the relevant documents are not complete, the brand does not conform to the requirements, and there are quality problems before your company puts them into use, enPrimo promises to return the goods unconditionally and supply qualified goods within the time specified by your company.

#### **When the products had issues after installation,**

- A. Please contact us immediately, and our sales and engineering teams will support you to help you solve the issue.
- B. If the battery is confirmed non-repairable even after repair within warranty, we will replace it for you within 1 month.

#### **6.Claim Payment Policy**

Claims under this Warranty must be made by notifying the supplier from whom the Product was purchased.